

Since 1898 performance and progress

Flame cutting
systems

Oxy-acetylene
equipment

Hot air welding
devices

ZINSER 1225-1 - Fiber Laser -

Gantry machine for laser and plasma cutting



STADLERS CORP FZC

CUTTING
WELDING

SINCE 1898

ZINSER

Fiber Laser

- user-friendly
- efficiency of 30% which is about three times higher than a CO²- Laser
- cutting power 1,5 kW? 3,0 kW of a CO² - Laser
- low maintenance costs

The ideal solution for laser and plasma cutting

High value guiding machine for laser and plasma cutting, ideal for combined cutting tasks. It unites the required speed for laser and plasma cutting with the robustness and longevity of an industrial machine. Dual side rack and pinion drive system (helical) via AC-servo motors and linear guides for the X- and Y-axes.

Advantages of a solid state laser compared to a CO₂ laser

The laser beam is guided in a glass fiber from the resonator to the beam generation system.

- no adjustment needed
- no need for gas purging of the beam path
- no maintenance of mirrors

Cutting power

- 1500 W of a fiber laser comparable to a 3000 W CO₂-Laser
- cutting thickness 1 - 13 mm

Safety Features

Completely enclosed machine housing for optimum safety for both the process and the operator.

A camera enables the control of the cutting process.

Control

The ZINSER controller and the guiding machine ZINSER 1225-1 are perfectly matched. As the user interface is very easy to handle the features of the machine will be optimally used.

The ZINSER programming system MCC and the integration of the CNC control into your network (intranet) minimizes the time between the CAD and the cut workpiece.

Technical data

Track width (C)	1.000 - 3.000 mm
Overall width of the machine (D)	track width (C) + 315 mm (+ power track chain + controller)
Machine length (E)	working length (B) + 1.000 mm
Machine housing	width (I) = track width (C) + 2.000 mm length (J) = machine length (E) + 1.000 mm height (H) = 2.600 mm
Width of the moveable cutting table (K)	working width (A) + 200 mm
Length of the moveable cutting table (L)	working length (B) + 300 mm
Number of torch carriers	max. 2
Cutting thickness	Laser 1-15 mm (depending on the laser source) Plasma 1-50 mm (depending on the power source)
Drive	AC-servo motor
Voltage	400 V / 50 Hz

Economic Advantages

Low investment costs

- very economical entry into the world of laser cutting
- profitable even with only temporary capacity utilisation

Low operating costs

- minimum cutting costs in laser quality

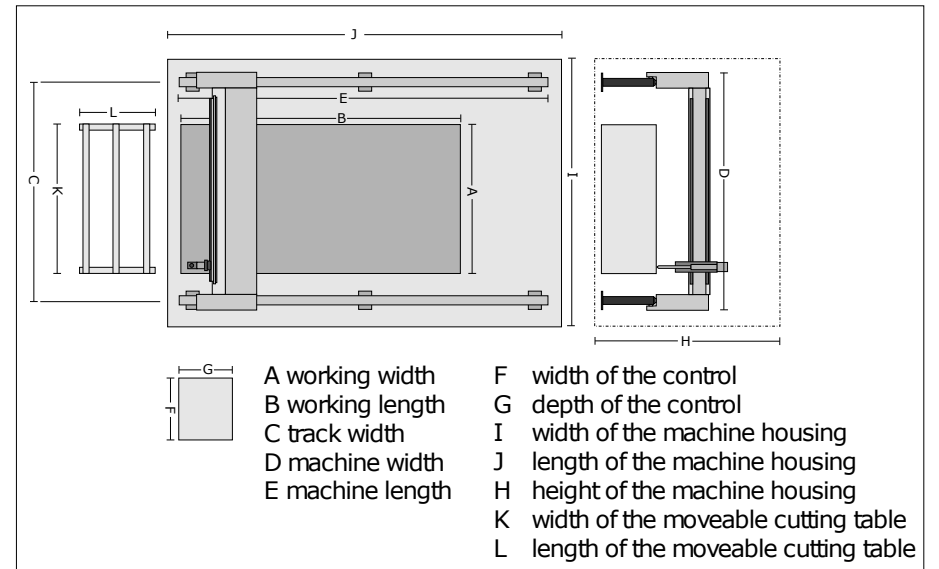

CUTTING
WELDING
SINCE 1898



Stadlers Corp FZC
Dubai - U.A.E.

Tel: +971 4 2382844

Fax: +971 4 2382855

info@stadlerscorp.com

www.stadlerscorp.com